

PERCUSSION AND ACCESSORIES



WELCOME TO THE WORLD OF SONOR PERCUSSION

**Rhythm is at the source of all musical experience.
As is the art of bringing sound to life.**

Rhythm is part of our daily life. It is the pulse that drives us, the steady beat that provides vitality and motion. Percussion instruments are basic elements of our music culture. The history of SONOR mirrors the excitement of historical and entrepreneurial challenges, in the same way that rhythm is linked to musical creativity and complexity. But throughout all the decades of SONOR history there remains one underlying theme: an uncompromising commitment to quality and dedicated craftsmanship.

In 1875 Johannes Link, a trained wood turner and tanner, started a small workshop for simple military drums and drum heads in Weißenfels an der Saale in East Germany. From these modest beginnings developed a flourishing business, which at the turn of the century already offered a comprehensive range of percussion instruments. In 1907 the SONOR trademark was registered with the Imperial Patent Office. Around 1925 SONOR had 145 employees and was one of the largest businesses of its kind.

After the end of World War II the East German Government expropriated the Link Family and SONOR became a state-owned enterprise. In 1946 a new company was established by the son of the founder, Otto Link, and his son Horst. This time the location was Aue in Westphalia/West Germany. Today SONOR has evolved into a modern enter-prise with its focus on the international markets.

Though latest technology has found its entry into SONOR production methods, the secret of the SONOR sound remains. It lies in the meticulous attention to even the smallest detail and the commitment of its founder to always maintain the highest possible level of quality.

**Only when sound is becoming a real experience,
the SONOR quality standard is met.
From precision craftsmanship musical expression
is shaped.**

Percussion instruments create a unique aura of fascination. Hardly another type of instrument except for maybe the human voice can connect people to music so directly and at the same time naturally. The vibrations of drum heads, of wood and metal bars touch human beings in a special way. The direct contact of your body with the instrument, the physical sensation of sound and the power of rhythm all this makes percussion a truly all-encompassing experience.

SONORs percussion range reintroduce you to the magic of fascinating sounds, rhythms and designs. With this catalog we would like to invite you to a journey through the world of percussion.

> Your SONOR percussion team

CONTENTS

Percussion Series	05
Congas	
Latino Congas	06
Global Congas	10
Champion Congas / Mini Congas	13
African Kpanlogos	14
Street Congas	15
Bongos	
Latino Bongos	16
Global Bongos	17
Champion Bongos / Champion Djembe	18
African Djembe	19
Latino Timbales	20
Cajones	
Latino Cajones	22
Premium Cajones	23
Global Cajones / Mini Cajon	24
DIY Cajones	25
Frame Drums & Tambourines	
Latino Frame Drums & Tambourines	26
Global Frame Drums & Tambourines	28
Metal Percussion	
Cowbells / Agogo Bells	30
Small Bells / Finger Cymbals	32
Triangles / Bar Chimes	33
Wood Percussion	
Wood / Temple / Sound Blocks	34
Wood Blocks / Claves / Effects	36
Guiro / Shekere / Maracas	38
Shaker	40
Hardware / Basic Arm	42
Accessories / Parts	46

ONE WORLD ONE DRUM

Your music – your style – your voice.

When it comes to your music, you want to express your style and very own voice. The SONOR percussion range is dedicated to the Percussion and Drumset player to find just the right instrument, no matter what style of music. But in every instrument we paid attention to the player's needs to build unique instruments that help express that voice – your voice.

Latino Series

The sound of all Latino instruments, including small percussions, is voluminous and powerful. High quality materials and lots of hand craftsmanship insure the unique sound.

All of the Latino Congas and Bongos are equipped with hand selected top quality buffalo skins and available with Oak shells from the best wood regions in the south of Thailand for that traditional tone, and fiberglass for cutting sounds and stability. Shock absorbing rubber floor rings on all Congas and Djembes add the comfort to your playing. When you are on the look out for a professional instrument, the wait is over.

Global Series

A wide range of high quality instruments at affordable prices – the Global Series. From Congas to Djembes to small percussion instruments, we got it covered. Curved Rims on all Congas make your playing more comfortable, stands are included. Both wood and fiberglass instruments are equipped with the same high quality buffalo skins that we use for our top-line instruments. See and hear the quality of all instruments including small percussions of the Global Series. Get a glimpse of the Global Series instruments today!

Champion Series

The Champion Series offers the most complete range of hand percussion instruments. Congas, Bongos and Djembes are available as well as small percussion instruments. We got it covered.



LATINO SERIES CONGAS

SONOR Latino Congas are available in fiberglass and hand selected Thai Oak, which comes from the best wood regions in the south of Thailand.

All instruments offer excellent sound characteristics, balanced tone and quality craftsmanship. These professional instruments are equipped with low mounted traditional rims, select buffalo skins, chrome-plated hardware and six tuning lugs on every drum to offer extra strength and easy tuning. A mounting bracket for double stands is included.

Specifications:

Height: 30", 2-ply Thai Oak (approx. 22 mm), buffalo head, chrome-plated traditional rim, rubber floor ring, 8 mm tension lugs, high gloss finishes



NHG Natural High Gloss

OBHG Ocean Blue High Gloss



DNHG Dark Natural High Gloss



LCSS
Conga Single Stand

*Thai Oak
Wood*



Latino, Thai Oak

LQW 11	11" Latino Quinto, height 30", 2-ply Thai Oak, buffalo skin, chrome-plated traditional rim, rubber floor ring
LCW 1175	11.75" Latino Conga (specifications see LQW 11)
LTW 1250	12.5" Latino Tumba (specifications see LQW 11)

Latino Stands

LQSS	Latino Quinto Single Stand - 11", height adjustable, black
LCSS	Latino Conga Single Stand - 11.75", height adjustable, black
LTSS	Latino Tumba Single Stand - 12.5", height adjustable, black

For accessories see page 46. For spare parts see page 47.

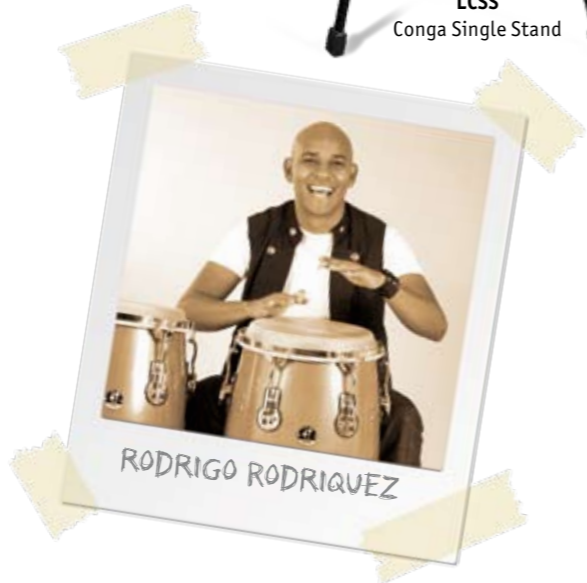

LATINO SERIES CONGAS

Latino, Fiberglass

LQF 11 11" Latino Quinto, height 30", fiberglass, buffalo skin, chrome-plated traditional rim, rubber floor ring

LCF 1175 11.75" Latino Conga (specifications see LQF 11)

LTF 1250 12.5" Latino Tumba (specifications see LQF 11)

For accessories see page 46. For spare parts see page 47.



Back View

DBHG Dark Blue High Gloss



RSHG Red Sparkle High Gloss

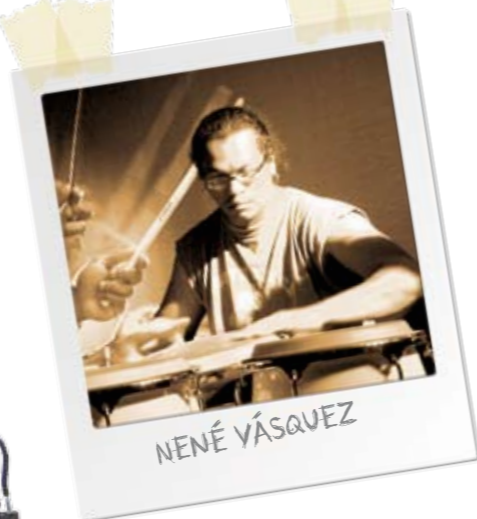

Fiberglass



GLOBAL SERIES CONGAS

The SONOR Global instruments offer a great start into the world of percussion and are available both in wood and fiberglass. The curved chrome rims provide a comfortable playing feel. With an excellent price performance ratio these instruments offer great sound and professional looks.

Specifications:

Height: 28", 2-ply Thai Oak (approx. 18 mm) or 3-ply fiberglass, buffalo heads, chrome-plated curved rims, rubber floor ring, 8 mm tension lugs, satin matte finishes, Congas incl. stand



NM Natural Matte

RM Red Matte

Back view



OFM Orange Fade Matte

Global, Thai Oak

GRW 10	10" Global Requinto, height 28", 2-ply Thai Oak, buffalo skin, chrome-plated curved rims, rubber floor ring, satin matte finishes, with single stand
GQW 11	11" Global Quinto, height 28" (specifications see GRW 10)
GCW 1175	11.75" Global Conga, height 28" (specifications see GRW 10)
GTW 1250	12.5" Global Tumba, height 28" (specifications see GRW 10)

For accessories see page 46. For spare parts see page 47.



HOLGER HÄLBIG

Thai Oak Wood



GLOBAL SERIES CONGAS

Fiberglass



BM Black Matte

Global, Fiberglass

- GRF 10 10" Global Requinto, height 28", fiberglass, buffalo skin, chrome-plated curved rims, rubber floor ring, satin matte finishes, with single stand
- GQF 11 11" Global Quinto, height 28" (specifications see GRF 10)
- GCF 1175 11.75" Global Conga, height 28" (specifications see GRF 10)
- GTFF 1250 12.5" Global Tumba, height 28" (specifications see GRF 10)

Global Stands

- GRSS Global Requinto Single Stand - 10", height adjustable, black
 - GQSS Global Quinto Single Stand - 11", height adjustable, black
 - GCSS Global Conga Single Stand - 11.75", height adjustable, black
 - GTSS Global Tumba Single Stand - 12.5", height adjustable, black
- For accessories see page 46. For spare parts see page 47.



NENÉ VÁSQUEZ

CHAMPION SERIES CONGAS

Hevea wood

The Champion line offers a full program of Congas, Mini Congas, Bongos and Djembes for beginners to intermediate players at very affordable prices.

The instruments are made to SONOR's specifications and feature Hevea wood shells, curved rims for comfortable playing feel, rubber floor rings or rubber feet, and buffalo heads.

Specifications:

Hevea wood, chrome-plated curved rims, rubber floor ring, high gloss finishes, Congas incl. stand

Champion Congas

- CR 10 10" Champion Requinto, height 28", Hevea wood, buffalo skin, Soft Rim/chrome, floor ring/rubber, single stand
- CQ 11 11" Champion Quinto (specifications see CR 10)
- CC 1175 11.75" Champion Conga (specifications see CR 10)
- CT 1250 12.5" Champion Tumba (specifications see CR 10)

Champion Mini Conga-Set

- CMC 0910 9" and 10" Champion Mini Conga Set, Hevea wood, buffalo skin, Soft Rim/chrome, with stand

Champion Stands

- BOST Bongo Stand, chrome-plated, double-braced legs, rubber feet
- For accessories see page 46. For spare parts see page 47.



SHG Sunburst



NHG Natural



RBHG Redburst



BBHG Blueburst

AFRICAN KPANLOGOS

Thai Oak Wood



The African Kpanlogo is one of the most popular drums originating from Ghana. Its sound makes it ideal for many different playing situations, from African rhythms to Caribbean and Brazilian styles. Also typical "conga grooves" can be played.

African Kpanlogo Features

- Available in 8", 10" and 11" sizes with a specially designed shell in 20" and 25" heights
- XLite Rim for maximum playing comfort
- Select buffalo skins offer authentic sound character
- Art Deco design motifs based upon African cave art

African Kpanlogos

	Thai Oak, buffalo skin, Soft Black/White finish, XLite Rim/chrome, floor ring/rubber
AK 8	8" African Kpanlogo, height 20", gazelle design
AK 10	10" African Kpanlogo, height 25", giraffe design
AK 11	11" African Kpanlogo, height 25", bird design

Bags

GBAK 8	Bag for African Kpanlogo 8"
GBAK 10	Bag for African Kpanlogo 10"
GBAK 11	Bag for African Kpanlogo 11"

For accessories see page 46. For spare parts see page 47.



STREET CONGAS

Fiberglass



RM Red / White

Street Congas were inspired by Boku, the original Cuban carnival drums. Their design developed from a careful modification of the authentic instrument. They offer a multitude of playing applications with different styles and are ideally suited for playing while walking (walking drums).

Street Conga Features

- Lightweight fiberglass shell
- Select buffalo skins offer authentic sound character
- Equipped with a carrying adapter for a strap
- Soundholes on the bottom of the shell for the best sound projection when placed on a floor
- Height adjustable stands available
- Shape and height adapted from fiberglass conga design
- Can easily be integrated into conga set-ups

Street Congas

SC 10	10" Street Conga, height 28", fiberglass, buffalo skin, Cuban Style Rim/chrome, carrying adapter, floor ring/rubber
SC 11	11" Street Conga (specifications see SC 10)

Stands and Bags

SCS 10	Single Stand - 10", steel, height adjustable, black
SCS 11	Single Stand - 11", steel, height adjustable, black
SCG	Street Conga carrying sling, nylon, black

GBSC 10	Bag for Street Conga 10"
GBSC 11	Bag for Street Conga 11"

For accessories see page 46. For spare parts see page 47.



BW Soft Black / White



LATINO SERIES BONGOS

SONOR Latino Bongos are available in fiberglass and hand selected Thai Oak, which comes from the best wood regions in the south of Thailand.

All instruments offer excellent sound characteristics, balanced tone and quality craftsmanship. These professional instruments are equipped with low mounted traditional rims, select buffalo skins, chrome-plated hardware and four tuning lugs on every bongo to offer extra strength and easy tuning.

Latino, Thai Oak

LBW 7850 7" and 8.5" Latino Bongo, Thai Oak, buffalo skin, chrome-plated traditional rim

Latino, Fiberglass

LBF 7850 7" and 8.5" Latino Bongo, fiberglass, buffalo skin, chrome-plated traditional rim

Latino Stands

LBS Bongo Stand, height adjustable, chrome
For accessories see page 46. For spare parts see page 47.

Thai Oak Wood



OBHG Ocean Blue High Gloss



NHG Natural High Gloss



DNHG Dark Natural High Gloss



DBHG Dark Blue High Gloss



RSHG Red Sparkle High Gloss

Fiberglass

GLOBAL SERIES BONGOS

The SONOR Global instruments offer a great start into the world of percussion and are available both in wood and fiberglass. The curved chrome rims provide a comfortable playing feel. With an excellent price performance ratio these instruments offer great sound and professional looks.

Thai Oak Wood

Global, Thai Oak

LBW 7850 7" and 8.5" Latino Bongo, Thai Oak, buffalo skin, chrome-plated traditional rim

Global, Fiberglass

LBF 7850 7" and 8.5" Latino Bongo, fiberglass, buffalo skin, chrome-plated traditional rim

Global Stands

LBS Bongo Stand, height adjustable, chrome
For accessories see page 46. For spare parts see page 47.



RM Red Matte



NM Natural Matte



OFM Orange Fade Matte

Fiberglass



BM Black Matte

CHAMPION SERIES BONGOS AND DJEMBE

The Champion line offers a full program of Congas, Mini Congas, Bongos and Djembes for beginners to intermediate players at very affordable prices.

The instruments are made to SONOR's specifications and feature Hevea wood shells, curved rims for comfortable playing feel, rubber floor rings or rubber feet, and buffalo heads.

Champion Bongos

CB 78 7" and 8" Champion Bongo, Hevea wood, buffalo skin, Soft Rim/chrome

CMB 45 4" and 5" Champion Mini Bongo, Hevea wood, buffalo skin, Soft Rim/chrome

Champion Djembe

CD 12 12" Champion Djembe, Hevea wood, goat skin, Soft Rim/chrome

Champion Stands

BOST Bongo Stand, chrome-plated, double-braced legs, rubber feet
For accessories see page 46. For spare parts see page 47.



NHG Natural

CMB 45



SHG Sunburst



RBHG Redburst

CB 78



BBHG Blueburst

AFRICAN DJEMBE

The Djembe is one of the most widespread African drums. Its combination of a dark, raw sound character and a bright, brilliant attack allows for a multitude of sounds. New playing techniques and styles have evolved over the years. The design motif is adapted from the Kpanlogo. Due to its lightweight hardware it offers a very comfortable playing feel. A carrying strap is available separately.

Djembe, Thai Oak

D 13 13" Djembe, height 25", bird design, Thai Oak, buffalo skin (0.5 mm), XLite Rim/chrome, carrying adapter, floor ring/rubber, Soft Black/White finish

Djembe Bag

GBD 13 Bag for Djembe 13"
For accessories see page 46. For spare parts see page 47.



Thai Oak Wood

LATINO SERIES TIMBALES

Two sets of SONOR Latino timbales are available, with steel or brass shells for a distinct sound with great projection. They are an ideal addition to any percussion or drum setup. A unique, patented 4-bolt swivel hinge for easy setup and quality SONOR engineering ensures reliability. These timbales feature easy handling and are "player-friendly".

Steel & Brass



Latino Timbales

- STI 1415 Timbales, 14" and 15", steel shell, with stand
- BTI 1314 Timbales, 13" and 14", brass shell*, with stand
- *) shown here with brass finish cowbells
- For accessories see page 46. For spare parts see page 47.



Unique, patented 4-bolt swivel hinge:
Open the hinge, place the timbales onto the stand, close the hinge – ready!



LATINO SERIES CAJONES

Latino Cajones

The new Latino Cajones come without any options. There is nothing to do for you, everything is perfect, that's what a Cajon has to be like – so, sit down and play!

The body of Latino Cajones is made of birch; the front plate is made of beech with two different exclusive veneers that add the exclusive look.

Latino Cajones

- | | |
|--------|---|
| CAJ WR | Front plate with exclusive Walnut Roots veneer, body made of birch, front plate made of beech, snare strainer mechanism, perfect snare and bass sounds, 49.5 x 30 x 30 cm (HxWxD) |
| CAJ BC | Front plate with exclusive Birdseye Cherry veneer, |



Latino Cajon Plus

The traditional Latino Cajon with Bamboo-Snare-Effect-System. This model has different sound possibilities due to an adjustable resonance hole and an upholstered seat made of genuine leather for a long and relaxed sitting.

The body of the Latino Cajon Plus is made of birch; the front plate is made of beech with a Bubinga veneer.

Latino Cajon Plus

- | | |
|--------|---|
| CAJ PL | Latino Cajon Plus, Front plate made of Bubinga, Bamboo-Snare-Effect-System, warm and earthy snare and bass sounds, different sound possibilities due to an adjustable resonance hole, upholstered seat made of genuine leather, 49.5 x 30 x 30 cm (HxWxD) |
|--------|---|

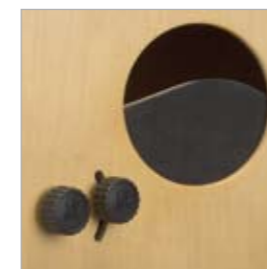

Adjustable resonance hole



Bamboo-Snare-Effect-System

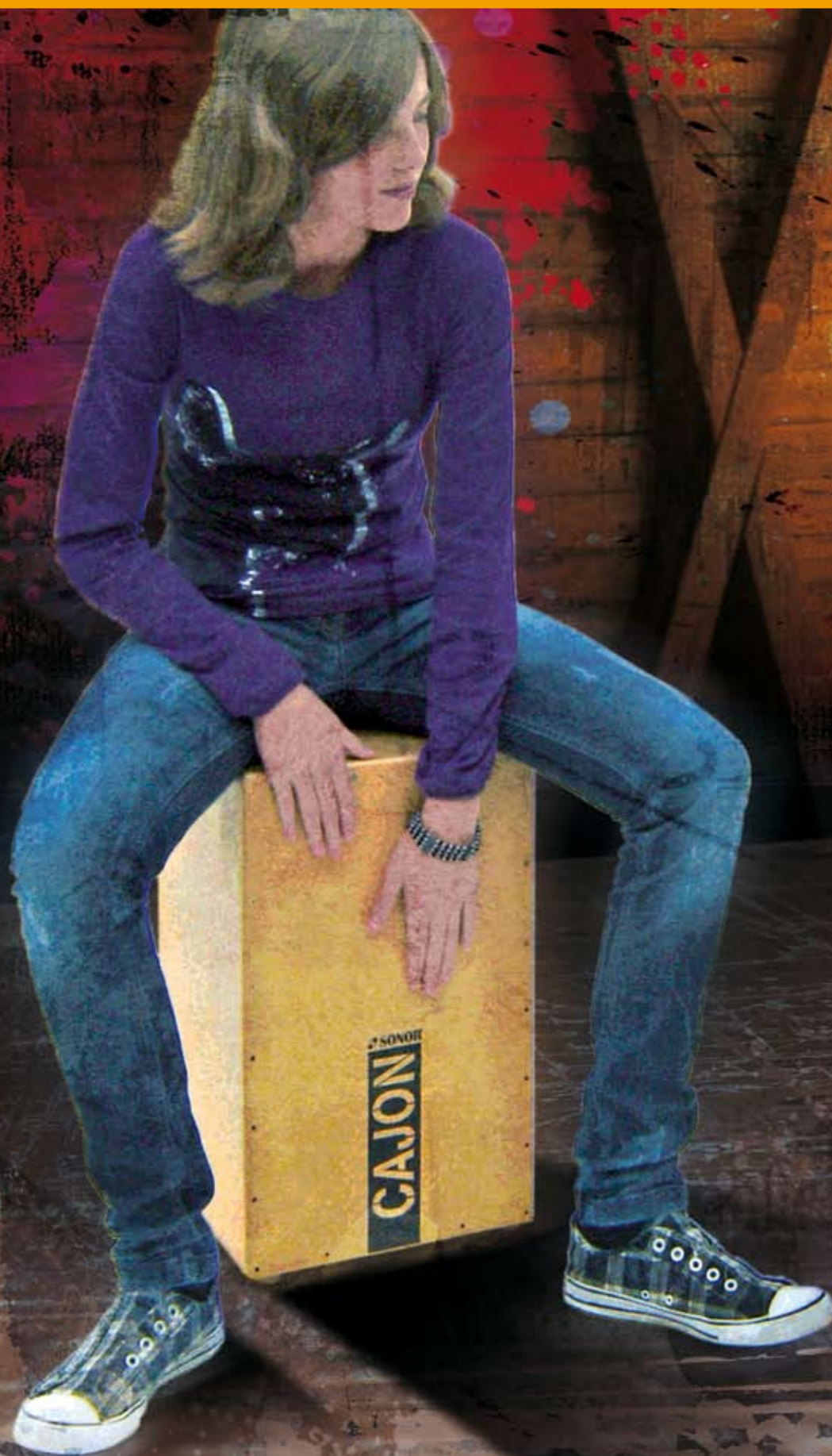

GLOBAL SERIES CAJONES

The Bamboo-Snare-Effect-System gives the Sonor Global cajones their unique warm, earthy snare and bass sounds. The high quality bodies are made of birch wood. Both models offer top quality at an affordable price.

Global Cajon

CAJ ST Front plate made of birch, Bamboo-Snare-Effect-System, warm and earthy snare and bass sounds, 48.5 x 30 x 30 cm (HxWxD)

Mini Cajon

CAJ ST Front plate made of birch, Bamboo-Snare-Effect-System, warm and earthy snare and bass sounds, 40.5 x 30 x 30 cm (HxWxD)



Bamboo-Snare-Effect-System



DIY CAJONES

The DIY "Do it yourself" Cajones are for you to assemble. The Cajones have been pre-assembled, so final assembly will only take approximately 20 minutes. The appropriate screwdriver is included. After sanding the edges the Cajon can be colored, stamped, printed, oiled, waxed or lacquered. There are no bounds on your creativity! The DIY Cajones are available in children's and adults' size.

DIY Cajon

CAJ DIY A Front plate made of birch, Bamboo-Snare-Effect-System, construction kit for adults, 48 x 30 x 30 cm (HxWxD)

CAJ DIY K Front plate made of birch, Bamboo-Snare-Effect-System, construction kit for children, 32 x 25 x 30 cm (HxWxD)

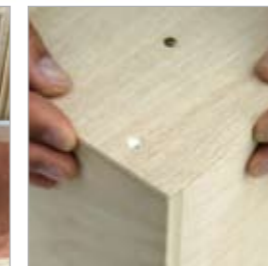
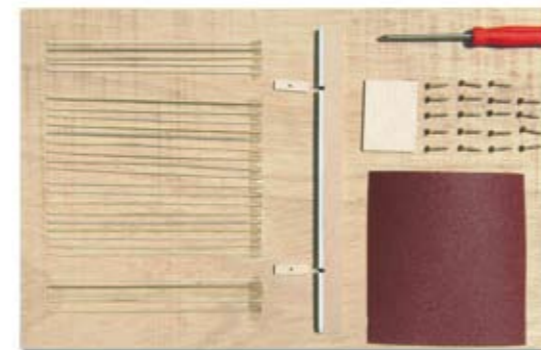

LATINO SERIES FRAME DRUMS

SONOR Latino Frame Drums and Tambourines are made according to high quality standards in a wide variety of designs and dimensions. Latino Frame Drums are available either with select natural skins or plastic heads for different sound characteristics and playing techniques. Natural skins offer a warmer tone, plastic heads sound dryer and are less sensitive to temperature changes.



Latino Frame Drums with tuneable natural skins

Beech wood frame with natural lacquer finish, nickel-plated tension hoops

LHDN 10	Frame Drum 10" (25 cm), 5 tension rods
LHDN 13	Frame Drum 13" (32 cm), 6 tension rods
LHDN 14	Frame Drum 14" (36 cm), 7 tension rods
LHDN 16	Frame Drum 16" (40 cm), 8 tension rods

Latino Frame Drums with tuneable plastic heads

Beech wood frame with natural lacquer finish, nickel-plated tension hoops

LHDP 10	Frame Drum 10" (25 cm), 5 tension rods
LHDP 13	Frame Drum 13" (32 cm), 6 tension rods
LHDP 14	Frame Drum 14" (36 cm), 7 tension rods

Latino Tambourines with tuneable plastic heads

Nickel silver jingles, beech wood frame with natural lacquer finish, nickel-plated tension hoops

LTA 6	Tambourine 10" (25 cm), 5 tension rods, 6 pairs of jingles
LTA 20	Tambourine 10" (25 cm), 5 tension rods, 20 pairs of jingles

Latino Headless Tambourine

LHT Headless Tambourine 10" (25 cm), 20 pairs of jingles

For accessories see page 46. For spare parts see page 47.

GLOBAL SERIES FRAME DRUMS



CG HD 8 N

CG T 8 N



GTS



CG THD 10 N

CG THD 10 P



CG TT 10 P



CG HT 10 D

Global Frame Drums with pre-tuned natural skins

Frame Drums with pre-tuned natural skins, wooden frames

- CG HD 8 N Frame Drum 8" (20 cm)
- CG HD 10 N Frame Drum 10" (25 cm) (not shown)

Global Frame Drums with tuneable natural skins

Frame Drums with tuneable natural skins, wooden frames

- CG THD 8 N Frame Drum 8" (20 cm), with beater, (not shown)
- CG THD 10 N Frame Drum 10" (25 cm), with beater
- CG THD 12 N Frame Drum 12" (30 cm), with beater, (not shown)

Global Frame Drums with tuneable plastic heads

Frame Drums with tuneable plastic heads, wooden frames

- CG THD 8 P Frame Drum 8" (20 cm), with beater, (not shown)
- CG THD 10 P Frame Drum 10" (25 cm), with beater
- CG THD 12 P Frame Drum 12" (30 cm), with beater, (not shown)



Global Tambourines with pre-tuned natural skins

Tambourines with pre-tuned natural skins, wooden frames

- CG T 6 N Tambourine 6" (15 cm), 5 pairs of jingles, (not shown)
- CG T 8 N Tambourine 8" (20 cm), 7 pairs of jingles
- CG T 10 N Tambourine 10" (25 cm), 9 pairs of jingles, (not shown)

Global Tambourines with tuneable natural skins

Tambourines with tuneable plastic heads, wooden frames

- CG TT 8 P Tambourine 8" (20 cm), 6 pairs of jingles, (not shown)
- CG TT 10 P Tambourine 10" (25 cm), 9 pairs of jingles
- CG TT 12 P Tambourine 12" (30 cm), 20 pairs of jingles, (not shown)

Global Headless Tambourines

CG HT 10 D Headless tambourine 10" (25 cm), 18 pairs of jingles, with wooden frame

CG HT 12 D Headless tambourine 12" (30 cm), 20 pairs of jingles, with wooden frame, (not shown)

GTS Tambourine Star, colored, 14 pairs of jingles with plastic frame and rubber grip
For accessories see page 46. For spare parts see page 47.

COWBELLS - AGOGO BELLS



Latino Cowbells, Brass Finish

- CB 4** Charanga Bell 4", brass finish, 3-sided wing screw, with mounting attachment
- CCB 5** Cha Cha Bell 5", brass finish, 3-sided wing screw, with mounting attachment
- CCB 55** Cha Cha Bell 5.5", brass finish, 3-sided wing screw, with mounting attachment
- MB 8** Mambo Bell 8", brass finish, 3-sided wing screw, with mounting attachment
- HB 8** Hand Bell 8", with rubber stripe damper 5, brass finish
For accessories see page 46. For spare parts see page 47.



A special 3-sided wing screw allows easy and quick attachment to a mounting arm or stand without interfering with the movement of the player.



Latino Agogo Bells, Brass Finish

- AGM** Agogo Bell, with mounting attachment, brass finish
- AGH** Agogo Bell, handheld, brass finish

Global Agogo Bell, Black Finish

- LAG** Agogo Bell, handheld, black

Global Cowbells, Black Finish

- GCB 4** Cowbell 4" (10 cm), with mounting attachment, black
- GCB 5** Cowbell 5" (12 cm), with mounting attachment, black
- GCB 7** Cowbell 7" (18 cm), with mounting attachment, black

Global Cowbells, Black Matt Finish

- CCB 55 BM** Cha Cha Bell 5", with mounting attachment and rubber stripe damper 3", black matt finish
- FB 65 BM** Fusion Bell 6.5", with mounting attachment and rubber stripe damper 3", black matt finish
- MB 8 BM** Mambo Bell 8", with mounting attachment and rubber stripe damper 5", black matt finish
For accessories see page 46. For spare parts see page 47.



SMALL BELLS - FINGER CYMBALS

Many metal percussion instruments were developed as a result of creative experiments with different objects and materials. Others, such as bells and jingles have centuries-old tradition. Often their unique character is unveiled through special playing techniques.

Latino Small Bells

GHB S	Hand Bells, small
GHB M	Hand Bells, medium
GSB	Sleigh Bells, with 9 bells

Global Small Bells

GBB	Brass Bells, cast, 1 pair
GFC 1	Finger Cymbals, 1 pair
GFC 2	Finger Cymbals, 2 pairs
V 4001	Wrist Bells with 6 small bells, white leather
V 4003	Sleigh Bells, with 6 large bells
V 4004	Hand Bells, with 5 bells
V 4002	Jingle Stick, 4 pairs of nickel silver jingles
GSS	Jingle Stick, 6 pairs of jingles

For accessories see page 46. For spare parts see page 47.



GBB

GFC 1

GFC 2



V 4001

V 4003



V 4004



GSB

GHB M

GHB S

GSS

V 4002



TRIANGLES - BAR CHIMES



LTR 10

LTR 18

LTR 15

BC 32

Latino Triangles

LTR 10	Triangle, silversteel, 4" (10 cm), with beater
LTR 15	Triangle, silversteel, 6" (15 cm), with beater
LTR 18	Triangle, silversteel, 7" (18 cm), with beater

Global Triangles

GTR 10	Triangle, 4" (10 cm), with beater
GTR 15	Triangle, 6" (15 cm), with beater
GTR 20	Triangle, 8" (20 cm), with beater

For accessories see page 46. For spare parts see page 47.



GTR 10

GTR 20

GTR 15

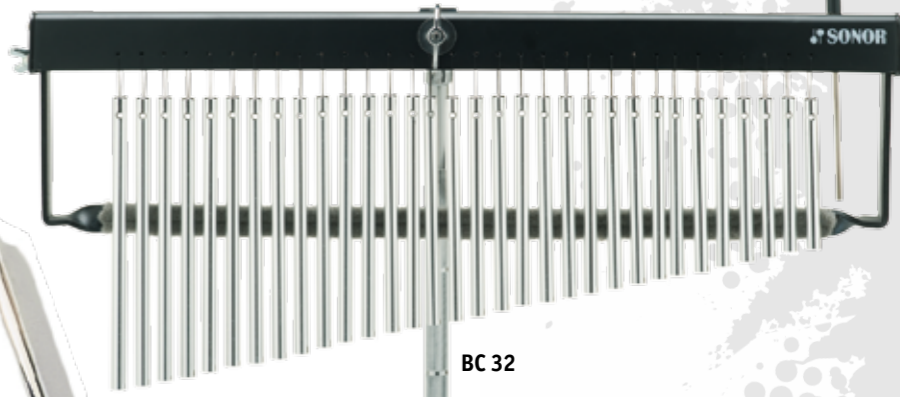

The Bar Chimes damper system



Latino Bar Chimes

BC 32	Bar Chimes with 32 silversteel chimes, damper and beater, ø 0.9 cm, length from 9.9 cm to 19 cm, without stand
-------	--

Global Bar Chimes

L 2639	Solid Bar Chimes, 36 tubular brass chimes, ø 0.8 cm, length from 3.5 cm to 20.9 cm, with height adjustable stand
--------	--

For accessories see page 46. For spare parts see page 47.



L 2639

TEMPLE AND SOUND BLOCKS

Our new 5-piece Temple Block set is designed for both classroom fun and professional use. The set comes with a newly designed mounting bar that enables it to be placed on a tabletop – perfect for school music classes. Still, professional percussion and drumset players can choose to mount the Temple Blocks with the attached clamps on a regular stand. Another feature is the ability to move the Temple Blocks on the mounting bar as desired. Some prefer to have the low blocks on the left side and the high ones on the right side – no problem. Go with whatever position is needed. Made out of Ash, the Blocks deliver dry and robust sounds.

Latino Temple Block Set

TT 5 5-piece Temple Block set, Ash wood, low to high pitch, mounting bar that enables it to be placed on a tabletop
For accessories see page 46. For spare parts see page 47.



Latino Wood Blocks

WB S Wood Block small, Ash wood, 3-sided wing screw for mounting attachment
WB M Wood Block medium, Ash wood, (specifications see WB S)
WB L Wood Block large, Ash wood, (specifications see WB S)



A special 3-sided wing screw allows easy and quick attachment to a mounting arm or stand without interfering with the movement of the player.



Latino Sound Blocks

SB M Sound Block medium in special Sonor design, 3-sided wing screw for mounting attachment



L 2611

Global Temple Blocks

L 2611 Korean Temple Blocks, 5-piece set, round design, harmonically arranged, with height adjustable stand and 1 special mallet
For accessories see page 46. For spare parts see page 47.

CLAVES - WOOD BLOCKS - EFFECTS

Wood idiophones are a large group of instruments coming from different cultures. They are used for basic rhythm patterns or for complex challenging playing styles. Like the originals SONOR wood percussion instruments are carefully handmade from select hardwoods. They have great sound quality and a cutting, powerful projection.

Claves belong to the basic setup of every percussionist. The SONOR CLA Claves are built after the original Cuban design with a cutout for better resonance and a conically shaped beater. They have an excellent cutting sound with high projection.

Latino Claves

CLA	Claves, Cuban design, with beater
LCL 1	Claves, rosewood, large, pair
LCL 2	Claves, rosewood, small, pair
LCL 3	Claves, original Mexican model, pair

Latino Wood Blocks

LWB 1	Wood Block, rosewood, length 13 cm, with beater
LWB 2	Wood Block, rosewood, length 18 cm, with beater
LWB 3	Wood Block, rosewood, length 13 cm, with beater

Global Wood Blocks

GWB S	Wood Block, length 16 cm, with beater
GWB L	Wood Block, length 18 cm, with beater

For accessories see page 46. For spare parts see page 47.



Latino Tone Blocks

LWA	Wooden Agogos, rosewood, with beater
LTU	Tone Block, rosewood, with beater

Global ToneBlocks

GTB	Tone Block, hardwood, length 20 cm, with beater
GDTB S	Double Tone Block, ø 3.5 cm, with beater
GDTB M	Double Tone Block, ø 4.5 cm, with beater



Global Effects

GCE	Circle Effect, tuned wooden bars, with beater
GRS	Wood Ratchet

For accessories see page 46. For spare parts see page 47.



GUIRO · SHEKERE



A Guiro is an important part of any percussion setup. Originally made of the calabash fruit, SONOR offers two fiberglass versions and one Mexican model which are very comfortable to play and have great sound projection.

Latino Guiros

FGL N	Guiro, fiberglass, large, Natural, with scraper
FGL B	Guiro, fiberglass, large, Soft Black, with scraper
FGL N	Guiro, fiberglass, small, Natural, with scraper
FGL B	Guiro, fiberglass, small, Soft Black, with scraper
L 2621	Guiro, Mexican style, with scraper

For accessories see page 46. For spare parts see page 47.



The Shekere is a traditional African instrument which is also popular in Caribbean music. The SONOR Shekere is made of fiberglass with adjustable tension of the beads and a clear, defined tone with great projection.

Latino Shekere

FS N	Shekere, fiberglass, Natural
FS B	Shekere, fiberglass, Soft Black

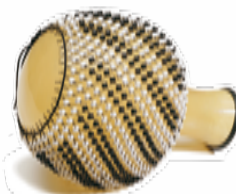

Shekere in Natural



FS B

MARACAS · EFFECTS

Maracas are among the best known percussion instruments and allow for many different ways of rhythmic accentuation and playing styles. Sonor Maracas are available in wood or plastic, giving a warmer or more defined, crisp sound.

Latino Maracas

L 2693	Maracas, Mexican style, wood, pair
--------	------------------------------------

Global Maracas

GMW S	Maracas, wood, small, pair
GMW M	Maracas, wood, medium, pair
GMW	Maracas, wood, round shape, pair
GMP	Maracas, plastic, black, pair
MMR	Mini Maracas, plastic, red, pair
MMBR	Mini Maracas, plastic, brown, pair

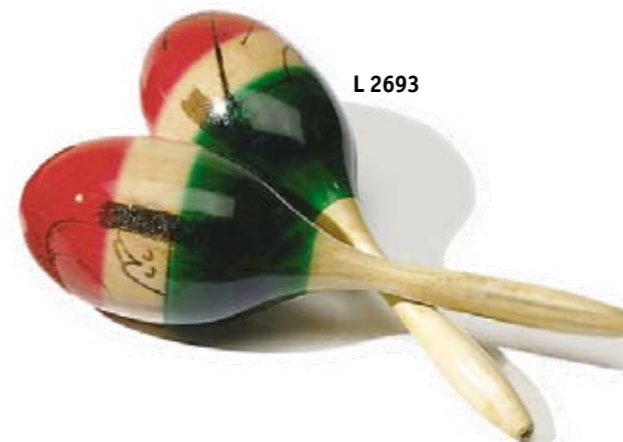

L 2693



MMBR

MMR

Latino Effects

LCAF	Cabasa Catena
LVS	Quijada
LCA	Castanets, rosewood



LCAF

LVS

LCA

SHAKERS

Caxixis are Shakers made of small, woven baskets in different sizes for a variety of rhythmical accents.

Latino Caxixis

LADS	African Double Shaker, natural
LCX S	Caxixi, small, natural
LCX M	Caxixi, medium, natural
LCX L	Caxixi, large, natural
LTC S	Tube Caxixi, small, natural, length 10 cm
LTC L	Tube Caxixi, large, natural, length 18 cm

Bamboo Shakers

NBS S	Natural Bamboo Shaker, small, 1" x 1.5"
NBS M	Natural Bamboo Shaker, medium, 2" x 1.5"
NBS L	Natural Bamboo Shaker, large, 3" x 1.5"
NBS	Natural Bamboo Shaker Set



Metal and Acrylic Shakers have a more cutting sound due to their material construction.

Latino Metal Shakers

LRMS S	Round Metal Shaker, length 16 cm
LRMS M	Round Metal Shaker, length 21 cm
LRMS L	Round Metal Shaker, length 27 cm
LSMS M	Square Metal Shaker, length 14 cm
LSMS L	Square Metal Shaker, length 26 cm

Global Metal Shakers

GMS	Metal Shaker, chrome, length 25 cm
LT	Tubo Metal Shaker, ø 5 cm, length 34 cm
V 2631	Shaker, ø 5 cm, length 7 cm

Acrylic Shakers

AS S	Acrylic Shaker, small, length 12.5 cm
AS M	Acrylic Shaker, medium, length 20 cm
AS L	Acrylic Shaker, large, length 25 cm



PERCUSSION HARDWARE

Multi Percussion Stand

This multi-functional stand adjusts to diameters from 6" to 26". Swivel arms to take a wide variety of shell forms and sizes such as Kpanlogos, Udu drums, djembes, etc. Height adjustable from 21" to 25". Rotational basket for easy setup and extendable legs for individual playing angles.

Multi Percussion Stand

MPS Multi Percussion Stand, adjusts to diameters from 6" to 26", black plated finish

Conga Floor Stand

CFS Conga Floor Stand, adjusts to diameters for all conga types, black plated finish

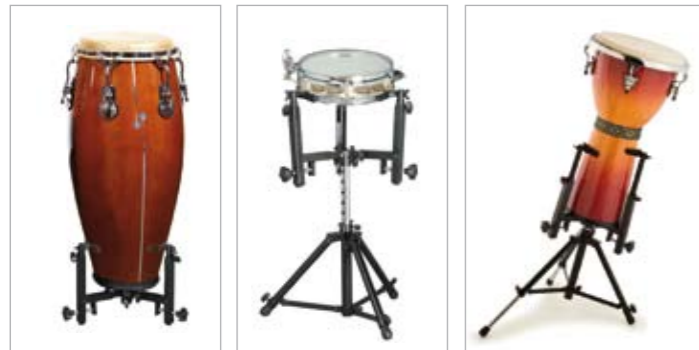

CFS

MPS

MPS

Latino Percussion Stands

LQSS	Latino Quinto Single Stand - 11", height adjustable, black
LCSS	Latino Conga Single Stand - 11.75", height adjustable, black
LTSS	Latino Tumba Single Stand - 12.5", height adjustable, black
LBS	Latino Bongo Stand, chrome finish

Global Percussion Stands

GRSS	Global Requinto Single Stand - 10", height adjustable, black
GQSS	Global Quinto Single Stand - 11", height adjustable, black
GCSS	Global Conga Single Stand - 11.75", height adjustable, black
GTSS	Global Tumba Single Stand - 12.5", height adjustable, black
GBST	Global Bongo Stand, black/chrome finish

Champion Percussion Stands

BOST	Bongo Stand, chrome finish
------	----------------------------



Global Conga Single Stand

Latino Conga Single Stand

Special Percussion Stands

CDST	Double Conga Stand, 4-bolt swivel hinge, player-friendly, easy handling, black/chrome finish
BST-L	Sit-down Bongo Stand, low mountable, black/chrome finish



BST-L



Sit-down Bongo Stand
Low mountable bongo stand for playing while seated. Takes most types of bongos.



LBS

77-108 cm



GBST

77-108 cm

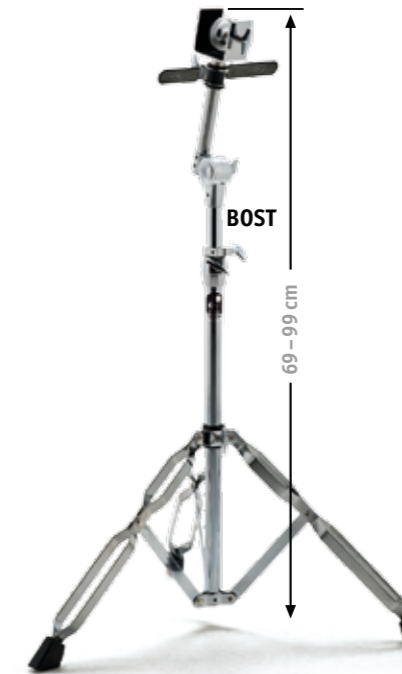

BOST

69-99 cm

Double Conga Stand

Unique, patented 4-bolt swivel hinge for easy setup and quality SONOR engineering to ensure reliability. Player-friendly and easy handling: **Open the hinge, place the conga drum onto the stand, close the hinge - ready.**

Can be used with all major conga brands.



CDST

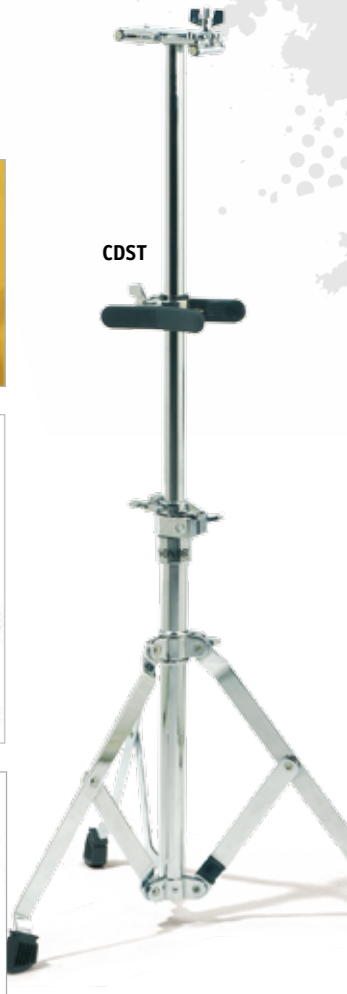

PERCUSSION HARDWARE

Flat Percussion Rack

The universal rack system enables you to mount a wide variety of small percussion instruments, such as cowbells or sound blocks.

Due to the included multi clamp the rack system can be mounted on most hardware stands. The ends of the cross bar can be pulled out and fixed with a wing screw at the desired length.

All these features provide a great amount of flexibility and reliable setups.

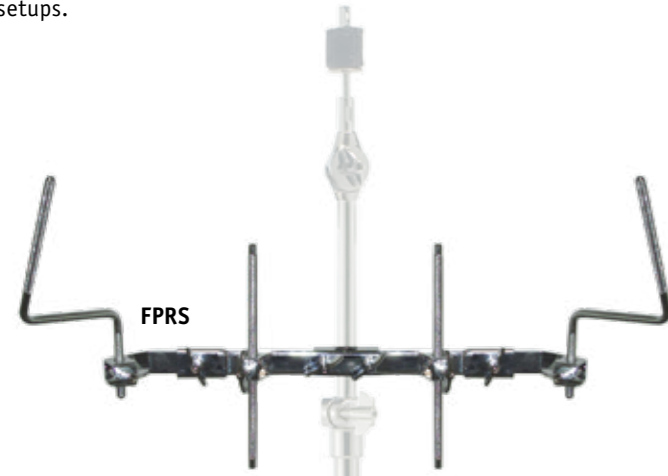

The ends of the cross bar can be pulled out and fixed with a wing screw

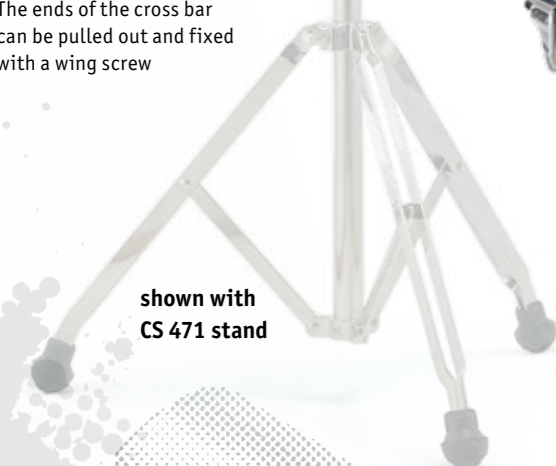

shown with CS 471 stand

Percussion Accessories

FPRS	Flat Percussion Rack with 4 accessory rods, chrome-plated finish, without stand
SPH	Small Percussion Holder with accessory rod, chrome-plated finish
MPHB	Percussion Holder, vertical rod with mounting clamp, black matte finish
PHB	Rod Extension Holder, more flexibility with the 180° rod, black matte finish
PT 12	Percussion Tray, 12" x 12", with felt surface, mountable on every standard stand, black

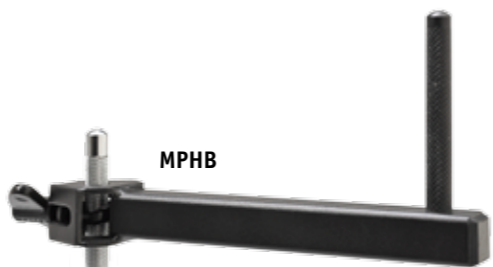

Mountable on every standard stand

HARDWARE 600 BASIC ARM SYSTEM

Basic Arm 19

BA19-S MC	Basic Arm 19, short, 150 mm
BA19-M MC	Basic Arm 19, medium, 220 mm
BA19-L MC	Basic Arm 19, long, 400 mm
BA19-BR	Basic Arm 19 Basic Ratchet
BA19-BDA	Basic Arm 19 Bass Drum Adapter
BA19-BSS MC	Basic Arm 19 Single Stand
BA19-BDS MC	Basic Arm 19 Double Stand

Basic Arm 12

BR12 MC	Basic Rack, with Arm 485 mm
BA12-S	Basic Arm 12, short, 285 mm
BA12-L	Basic Arm 12, long, 485 mm
BA12-BR	Basic Arm 12 Basic Ratchet

Basic System

BA-CH	Basic Arm Cymbal Holder
BA-PA	Basic Arm Percussion Adapter
BA-TA	Basic Arm Tom Adapter
BA-BC	Basic Arm Basic Clamp
BA-CR	Basic Arm Connection Ratchet
BA-TB	Basic Arm Tele Boom
BA-MA	Basic Arm Microphone Adapter

Freedom, Flexibility and Function

The Basic Arm System utilizes a vast array of arms, ratchets and adapters to create the ultimate in flexibility, freedom and function, allowing you to create your own customized individual hardware setup. The Basic Arm System is divided into the Basic Arm 19 and Basic Arm 12, reflecting the variation in tube diameters.

We utilize identical ratchets overall for ease of compatibility between the components. Experiment and design the Basic Arm System of your own.

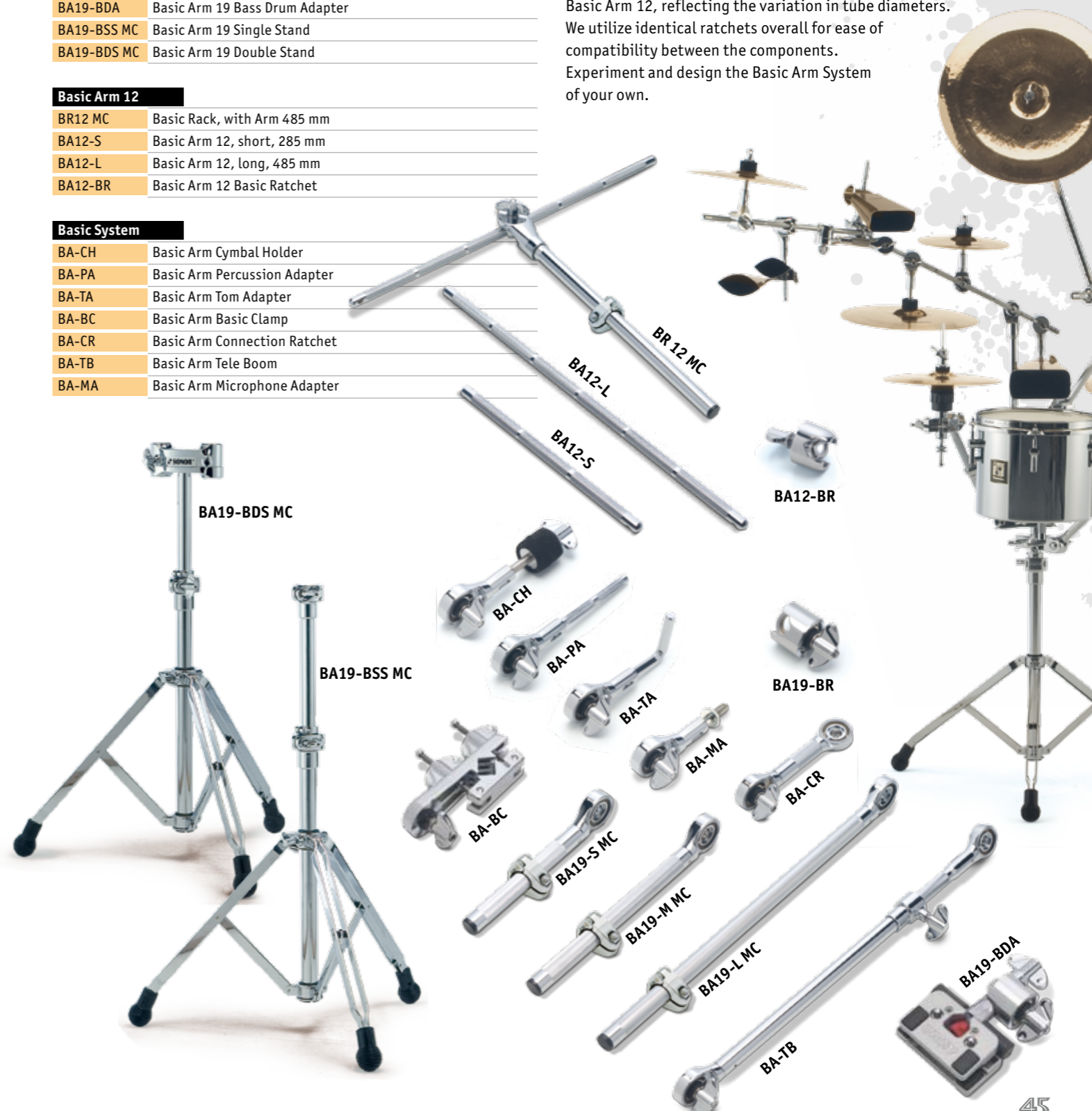

ACCESSORIES

Percussion Mallets

SCH 2	Mallet with rubber head, for Wood Percussion
SCH 3	Mallet with rubber head, for Wood Percussion
SCH 5	Mallet with felt head, hard, for Temple Blocks
SCH 6	Mallet with felt head, medium, for Frame Drums
SCH 7	Mallet with felt head, hard, for Frame Drums
SCH 16	Mallet with thread head, for Tubular Chimes
SCH 17	Mallet with felt head, small, for Frame Drums
SCH 95	Mallet with wood head, for Wood Percussion

Drum Sticks

Z 5640	Drum sticks, maple, pair
Z 5642	Drum sticks, hickory, pair, (not shown)

Bags for Drums & Percussion

GBAK 8	Bag for African Kpanlogo 8"
GBAK 10	Bag for African Kpanlogo 10"
GBAK 11	Bag for African Kpanlogo 11"
GBD 13	Bag for Djembe 13"
GBSC 10	Bag for Street Conga 10"
GBSC 11	Bag for Street Conga 11"
GBCO 1011	Bag for Quinto 10" / 11"
GBCO 1175	Bag for Conga 11.75"
GBCO 1250	Bag for Tumbadora 12.5"
GBPE	Bag for small percussion and Bongo
SSB	Sonor stick bag

Carrying Sling

SCG	Carrying sling for Street Conga/Djembe, nylon, with velcro adjustment
-----	---



PARTS

Article No.

80300319	Tension hook for hand drum (Latino)
90549901	Conga head 10" (Champion)
90549902	Conga head 11" (Champion)
90549903	Conga head 11.75" (Champion)
90549904	Conga head 12.5" (Champion)
90549905	Bongo head 7" (Champion)
90549906	Bongo head 8" (Champion)
90549908	Mini Conga head 9" (Champion)
90549909	Mini Conga head 10" (Champion)
90549910	Conga rim 10" (Champion)
90549911	Conga rim 11" (Champion)
90549912	Conga rim 11.75" (Champion)
90549913	Conga rim 12.5" (Champion)
90549914	Bongo rim 7" (Champion)
90549915	Bongo rim 8" (Champion)
90549916	Djembe rim 12" (Champion)
90549917	Mini Conga rim 9" (Champion)
90549918	Mini Conga rim 10" (Champion)
90549919	Bracket for Conga (Champion)
90549920	Bracket for Djembe (Champion)
90549921	Bracket for Mini Conga (Champion)
90549922	Conga tension hook (Champion)
90549923	Mini Conga tension hook (Champion)
90549924	Bongo tension hook (Champion)
90549925	Djembe tension hook (Champion)
90549926	Rubber feet Conga single stand Champion (3 pcs)
90549927	Rubber feet Mini Conga stand Champion (3 pcs)
90549928	Rubber feet Bongo stand Champion (3 pcs)
90549930	Djembe head 12" (Champion)
90549931	Mini Bongo head 4" (Champion)
90549932	Mini Bongo head 5" (Champion)
90549936	Plastic head for hand drum (Global)
90549937	Plastic head for hand drum CG THD/CG TT 10P
90549938	Plastic head for hand drum CG THD/CG TT 12P

Article No.

90549939	Natural head incl. rim for hand drum 8" (Global Series)
90549940	Natural head incl. rim for hand drum 10" (Global Series)
90549941	Natural head incl. rim for hand drum 12" (Global Series)
99600600	Djembe head 13" (D13)
99600700	African Kpanlogo head 10"
99600800	African Kpanlogo head 11"
99601900	African Kpanlogo head 8"
99602000	Street Conga head 10"
99602100	Street Conga head 11"
99602400	Street Conga rim 10"
99602500	Street Conga rim 11"
99602600	Timbale head 14"
99602700	Timbale head 15"
99602800	Timbale head 13"
99603100	Conga head 11" (Latino)
99603200	Conga head 11.75" (Latino)
99603300	Conga head 12.5" (Latino)
99603400	Bongo head 7" (Latino)
99603500	Bongo head 8.5" (Latino)
99605100	Conga rim 11" (Latino)
99605200	Conga rim 11.75" (Latino)
99605300	Conga rim 12.5" (Latino)
99605400	Bongo rim 7" (Latino)
99605500	Bongo rim 8.5" (Latino)
99607900	Conga mounting bracket for Conga double stand
99608000	Conga tension hook (Latino/Global)
99608100	Bracket for Conga (Latino/Global)
99608300	Bracket for Street Conga/Kpanlogo
99608500	Bongo tension hook (Latino/Global)
99608600	Djembe tension hook (Latino/Global)

Article No.

99610000	Rubber feet for Conga stand Latino (3 pcs)
99610100	Rubber feet for Bongo stand Latino (3 pcs)
99610200	Rubber feet for Conga stand Global (3 pcs)
99610400	Rubber feet for Timbales stand (3 pcs)
99610500	Rubber feet for Street Conga stand (3 pcs)
99610600	Rubber feet for Conga stand CDST/BST-L/GBST (3 pcs)
99610700	U-Clamp for Bongo stand BST-L/LBS/GBST
99610800	Wing nut for Cowbell CCB 55 BM/FB 65 BM/MB 8 B
99610900	Wing nut for Cowbell CB 4/CCB 5/CCB 55/MB 8
99620000	Conga head 10" (Global)
99620100	Conga head 11" (Global)
99620200	Conga head 12.5" (Global)
99620400	Bongo head 7" (Global)
99620500	Bongo head 8.5" (Global)
99620600	Conga rim 10" (Global)
99620700	Conga rim 11" (Global)
99620800	Conga rim 11.75" (Global)
99620900	Conga rim 12.5" (Global)
99621000	Bongo rim 7" (Global)
99621100	Bongo rim 8.5" (Global)
99623000	Conga rim 10" (Global)
99623100	Conga rim 11" (Global)
99623200	Conga rim 11.75" (Global)
99623300	Conga rim 12.5" (Global)
99623400	Bongo rim 7" (Global)
99623500	Bongo rim 8.5" (Global)
99624500	African Kpanlogo rim 8"
99624600	African Kpanlogo rim 10"
99624700	African Kpanlogo rim 11"
99850600	Tension hook for hand drum (Global)





ONE WORLD
ONE DRUM